



ITEM # \_\_\_\_\_

MODEL # \_\_\_\_\_

NAME # \_\_\_\_\_

SIS # \_\_\_\_\_

AIA # \_\_\_\_\_

## Turbo Liquidizers TBXPro with soup head, 1 speed



**602169 (DTBXPROIT)**

TBX Pro Turboliquidizer with soup head, 1 speed, 1650 rpm, 380-415V, 3ph, 50Hz

### Short Form Specification

Item No. \_\_\_\_\_

Constructed entirely in stainless steel and mounted on a trolley with 4 wheels with brakes. Fast and simple height adjustment (250mm range). Can be adapted to all types of pots. Equipped with tube and tool for mixing and blending soups and other semi-liquids or liquids. Safety device allows the machine to start only when in working position. All components of tube and head are in stainless steel and dishwasher safe (excluding bearings). 1 speed: 1650 rpm. The touch button control panel has IP65 protection with low voltage level.

### Main Features

- Used to mix, blend and emulsify vegetable and soups, fruit and vegetable purées, liquid pastries, sauces and much more directly in cooking pots/containers.
- Appliance equipped with tube and tool for mixing and blending soups and other semi-liquids or liquids.
- Equipped with crank handle for fast and easy height adjustment.
- Mixer tube is easily removable without tools and can be dismantled in separate parts: tube, shaft, bearing and rotor.
- All components of tube and head are in stainless steel and dishwasher safe (excluding bearings).
- Safety device allows the machine to start only when it is in a working position.
- Suggested for pots containing up to 700 liters of liquid.
- Turbine accelerates the flow of the liquid over the impeller providing a greater throughput and finer grinding.

### Construction

- 1 speed: 1650 rpm.
- 220-240V/50Hz/3-phase available on request.
- Power: 1500 watts.
- Constructed entirely in stainless steel to offer maximum durability.
- Mounted on a mobile stainless steel trolley (4 wheels with brakes). Storage position: fold down motor/arm to save space.
- Trolley with support to store up to two tubes (with assembled tool).
- CE approved (Machine Directive) with CB test report from third party notified body.
- IP65 waterproof control panel, IP23 throughout the entire machine.
- 250mm height adjustment range for the motor body. Different tube lengths allow to adapt to pot depths (see optional accessories).
- All parts in contact with food are conform to 1935/2004/EC.
- Equipped with 8 m power cord without plug.

### Included Accessories

- 1 of TBX Pro soup head PNC 650172 (without tube)
- 1 of TBX Pro medium tube PNC 650175 448 mm

APPROVAL: \_\_\_\_\_

Front

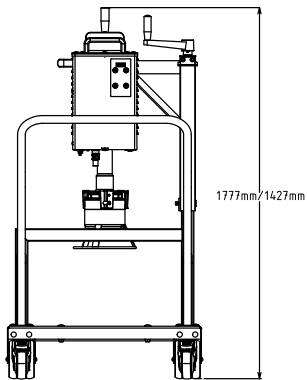

Side

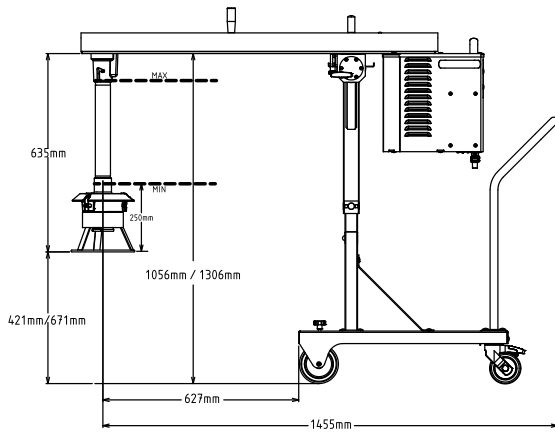

EI = Electrical inlet  
(power)

Top

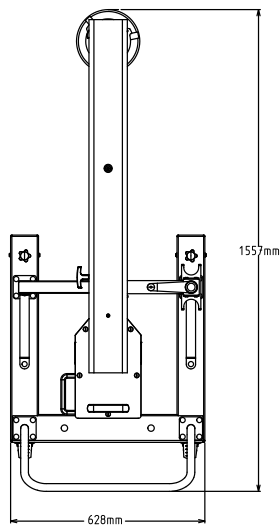

## Electric

### Supply voltage:

**602169 (DTBXPROIT)** 380-415 V/3 ph/50 Hz

### Electrical power max.:

1.5 kW

### Total Watts:

1.5 kW

### Plug type:

Cable without plug

## Key Information:

### External dimensions, Width:

628 mm

### External dimensions, Depth:

1556 mm

### External dimensions, Height:

1122 mm

### Net weight:

80 kg

### Shipping weight:

94 kg

### Height adjustment:

1122/1372 mm

### Approvals

UKCA;CE;CB

### Waterproof index:

IP23

### Number of speeds:

1

### Rotation speed:

1

Turbo Liquidizers  
TBXPro with soup head, 1 speed

The company reserves the right to make modifications to the products  
without prior notice. All information correct at time of printing.